

ESD Protection Diode in DFN0603

Features

- 80Watts peak pulse power ($t_p = 8/20\mu s$)
- Tiny DFN0603 package
- Bidirectional configurations
- Solid-state silicon-avalanche technology
- Low clamping voltage
- Low leakage current
- Response time is typically $< 1ns$
- Medium capacitance ($C_j = 15pF$ typ.)
- Protection one data/power line to:
 - IEC 61000-4-2 $\pm 30kV$ contact $\pm 30kV$ air
 - IEC 61000-4-4 (EFT) 40A (5/50ns)
 - IEC 61000-4-5 (Lightning) 8A (8/20 μs)

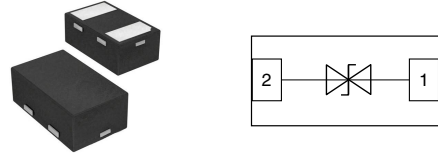

Mechanical Data

- **Case:** DFN0603 (plastic package).
Lead free; RoHS compliant; Halogen free
- **Molding Compound Flammability Rating:**
UL 94 V-0
- **Terminals:** High temperature soldering guaranteed:
260 °C/10 sec. at terminals

Applications

- Cell Phone Handsets and Accessories
- Microprocessor based equipment
- Personal Digital Assistants (PDA's)
- Notebooks, Desktops, and Servers
- Portable Instrumentation

Absolute Maximum Ratings

Ratings at 25 °C, ambient temperature unless otherwise specified

Parameter	Symbol	Value	Unit
Peak Pulse Power ($T_p=8/20\mu s$)	P_{PP}	80	W
ESD contact/air discharge (IEC-61000-4-2)	V_{ESD}	30/30	kV
Peak Pulse Current ($T_p = 8/20\mu s$)	I_{PP}	8	A
Junction Temperature	T_J	-55 to +125	°C
Storage temperature	T_{STG}	-55 to +150	°C
Maximum Lead Solder Temperature(10 second duration)	T_L	260	°C

Electrical Characteristics

($T_A = 25$ °C unless otherwise specified)

Parameter	Symbol	Condition	Min	Typ	Max	Unit
Reverse stand-off Voltage	V_{RWM}				7	V
Reverse Breakdown Voltage	V_{BR}	$I_T=1mA$	7.2			V
Reverse Leakage Current	I_R	$V_{RWM}=7V$			1	μA
Clamping Voltage	V_C	$I_{PP}=8A, T_p=8/20\mu s$		10		V
Junction Capacitance	C_J	$V_R=0V, f=1MHz$		15		pF

Typical Characteristics ($T_{amb} = 25\text{ }^{\circ}\text{C}$ unless otherwise specified)

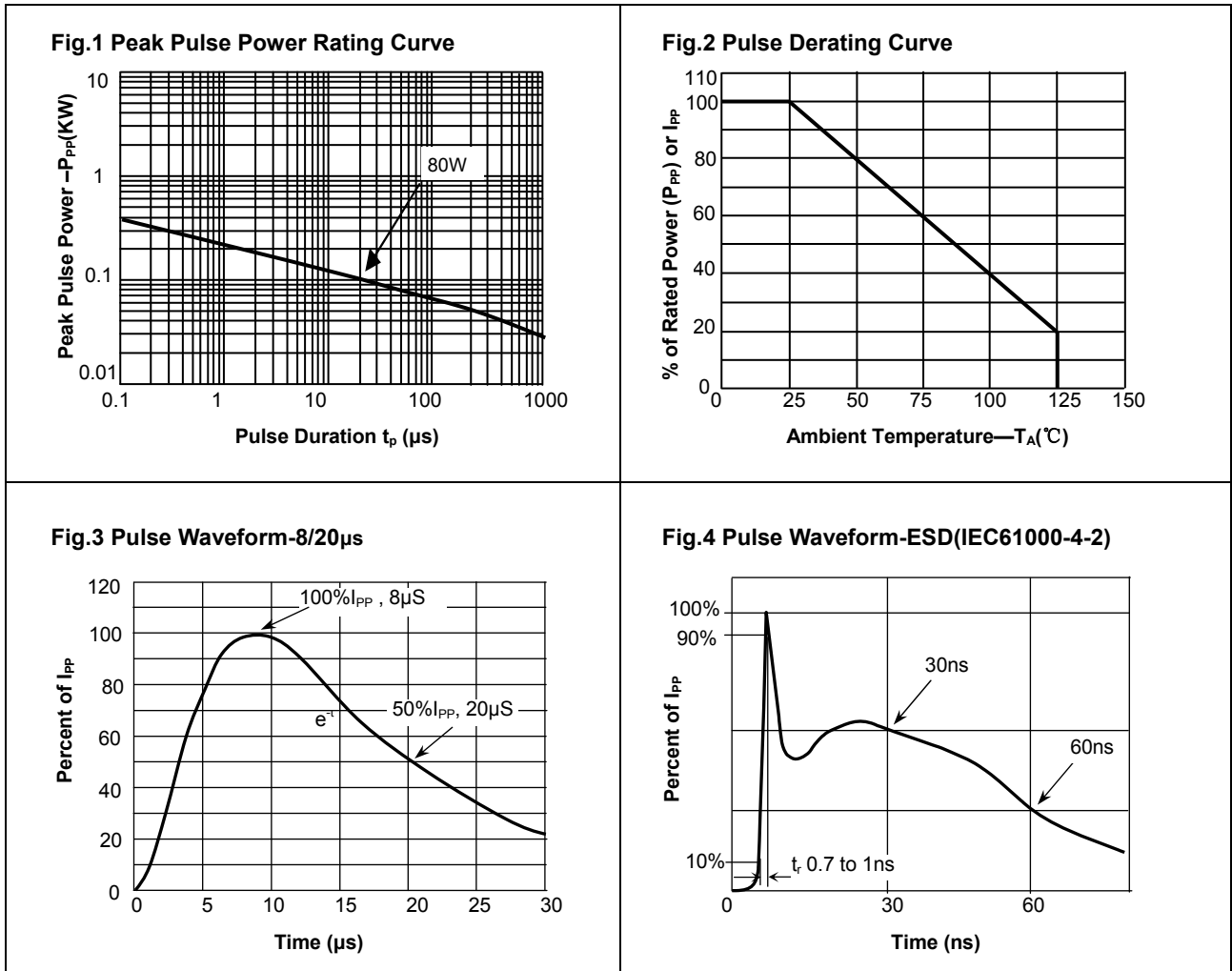

Package Dimensions

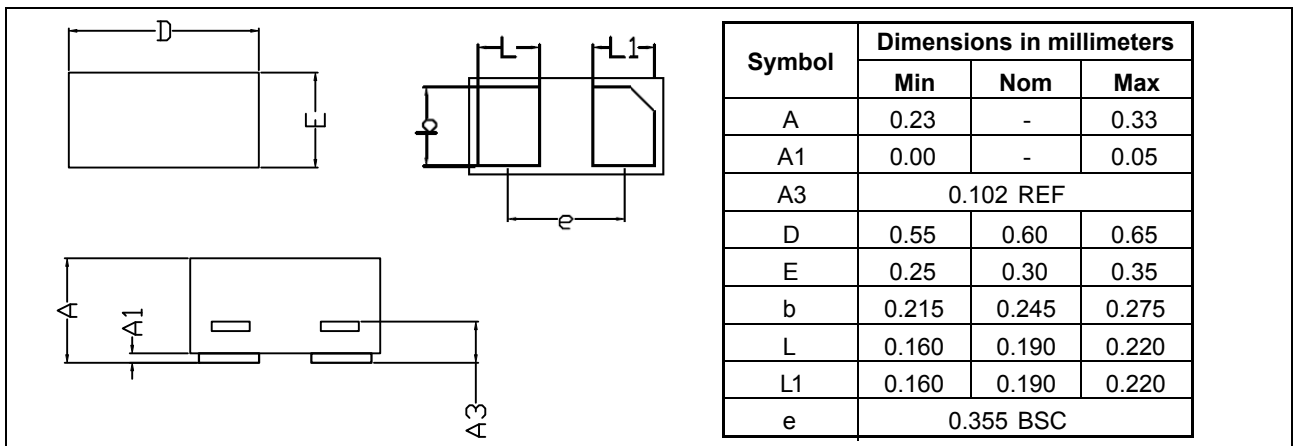

Pad Dimensions

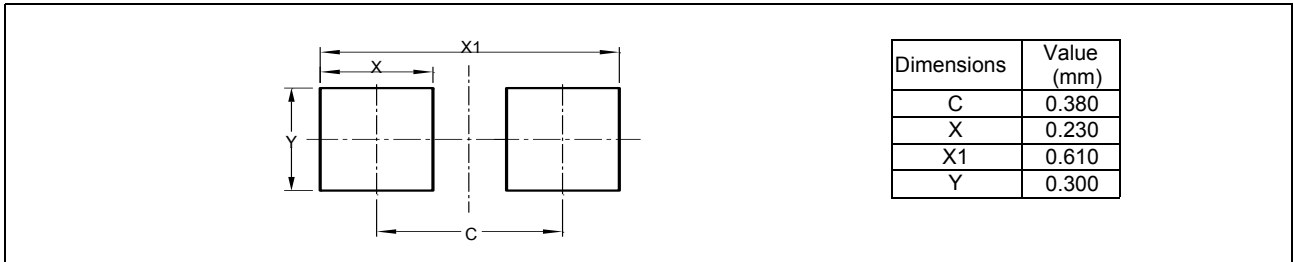

Package Information

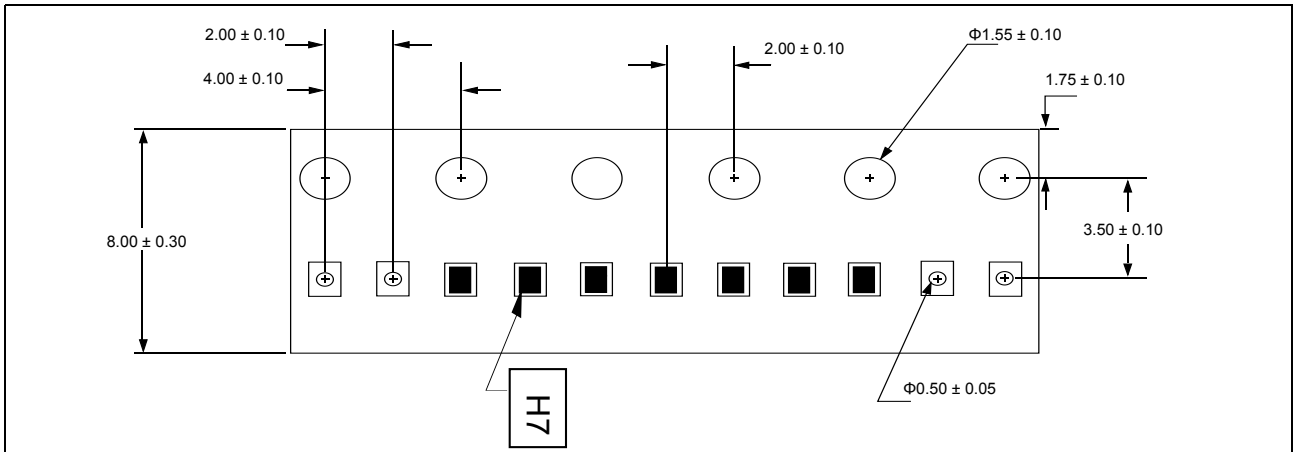

Marking



Ordering information

Order code	Package	Packaging option	Base quantity	Packaging specification
TESD0603NC7VB	DFN0603	Tape and reel	10000pcs / reel	EIA STD RS-481