

Ultra Low Capacitance ESD Protection '8]cXY']b`DFN0603

: YUi fYg

- 50Watts peak pulse power (tp = 8/20us)
- DFN0603 package
- Bidirectional configurations
- Solid-state silicon-avalanche technology
- Low clamping voltage
- Low leakage current
- Medium capacitance (CJ=0.2pF typ.)
- Protection one data/power line to:
 - IEC 61000-4-2 ±18kV contact ±18kV air
 - IEC 61000-4-4 (EFT) 40A (5/50ns)
 - IEC 61000-4-5 (Lightning) 7A (8/20μs)

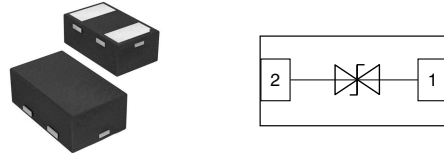

A YW Ub]WU`8 UU

- 7 UgY. DFN0603 (plastic package).
Lead free; RoHS compliant; Halogen free
- Ac`X]b[`7 ca dci bX': `Ua a UW]]hmF UH]b[.
UL 94 V-0
- Hyfa]bUg. High temperature soldering guaranteed:
260 °C/10 sec. at terminals

Applications

- Cell Phone Handsets and Accessories
- Personal Digital Assistants (PDA's)
- Microprocessor based equipment
- Notebooks, Desktops, and Servers
- Portable Instrumentation

5 Vgc`i hY`AU]a i a `FU]b[g

Ratings at 25 °C, ambient temperature unless otherwise specified

Parameter	Symbol	Value	Unit
Peak Pulse Power (TP=8/20μS)	PP	50	W
ESD contact/air discharge (IEC-61000-4-2)	VESD	18/18	kV
Peak Pulse Current (tp = 8/20μS)	IPP	7	A
Junction Temperature	TJ	-55 to +125	°C
Storage temperature	TSTG	-55 to +150	°C

Electrical Characteristics

(TA = 25 °C unless otherwise specified)

Parameter	Symbol	Condition	Min	Typ	Max	Unit
Reverse stand-off Voltage	VRWM				5.0	V
Holding Voltage	VH	IT=IH	2.0		5.0	V
Holding Current	IH		15			mA
Reverse Leakage Current	IR	VRWM=5V			500	nA
Clamping Voltage	VC	IPP=7A, TP=8/20μs		6.0	7.5	V
Clamping Voltage(TLP)	VC	IPP=16A, TP=100ns		7.0		V
Trigger Voltage	VT		8		16	V
Dynamic Resistance	Rdyn	TP=100ns		0.25		Ω
Junction Capacitance	CJ	VR=0V, f=1MHz (IO/IO)		0.2		pF

Typical Characteristics ($T_{amb} = 25\text{ }^{\circ}\text{C}$ unless otherwise specified)

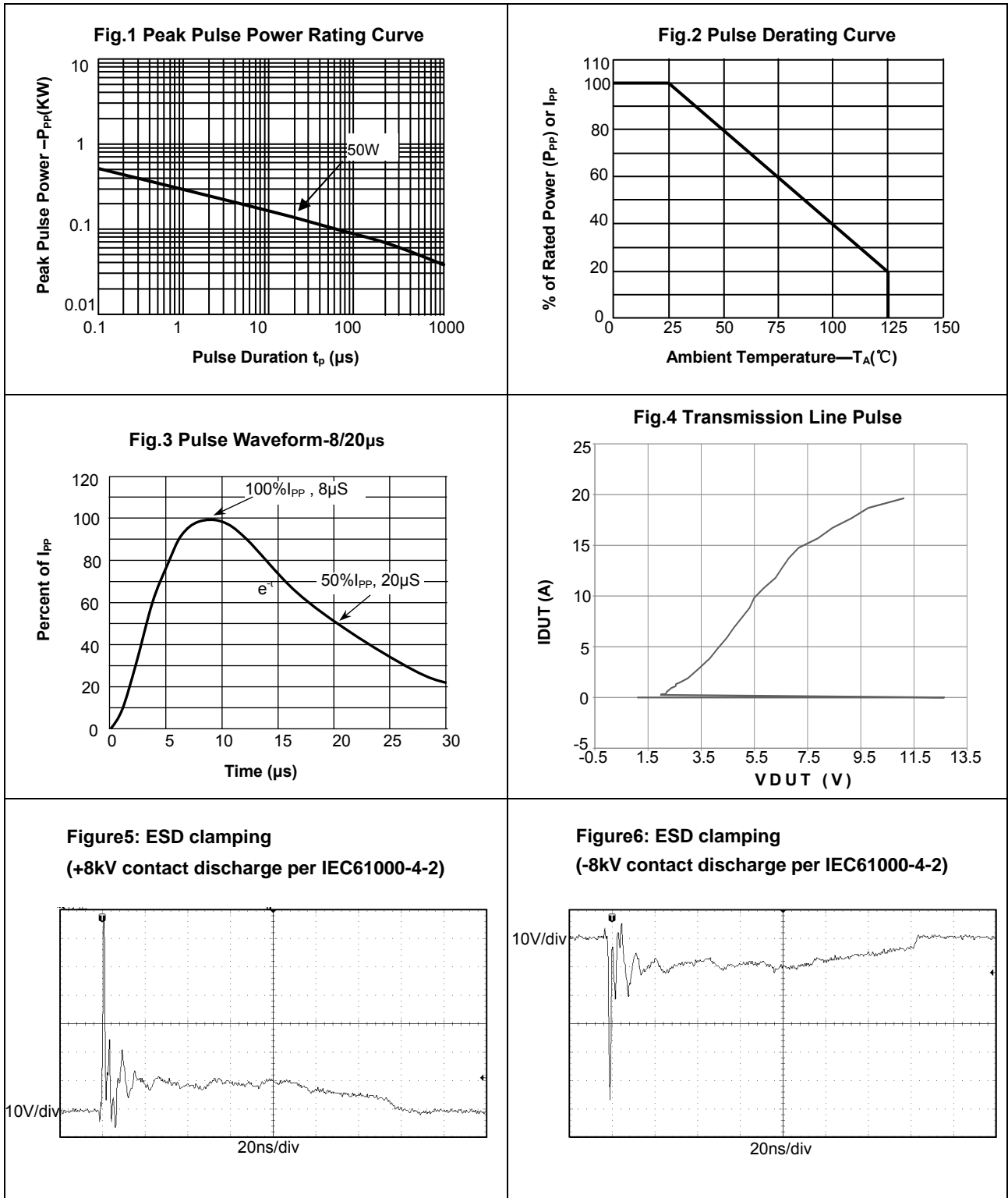

Package Dimensions

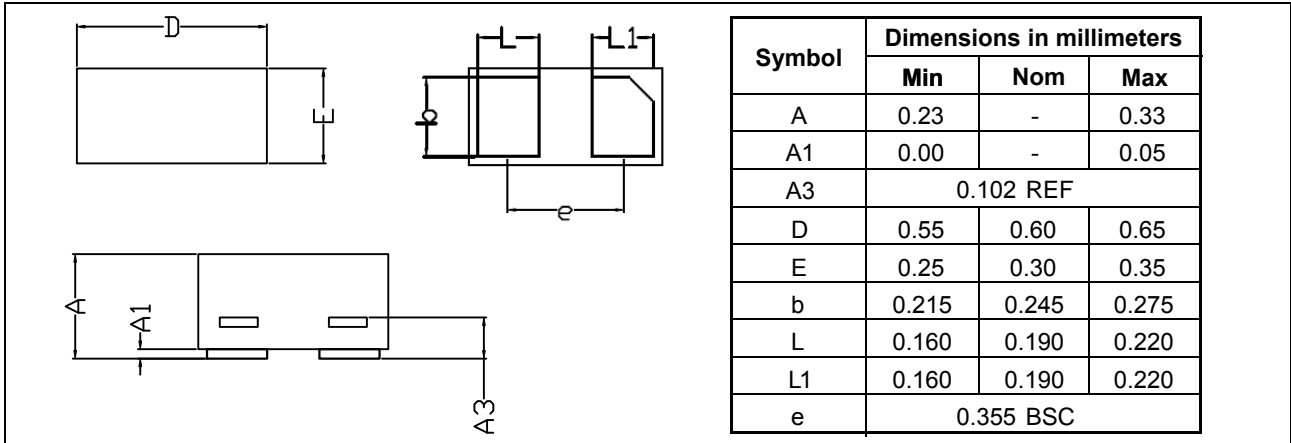

Pad Dimensions

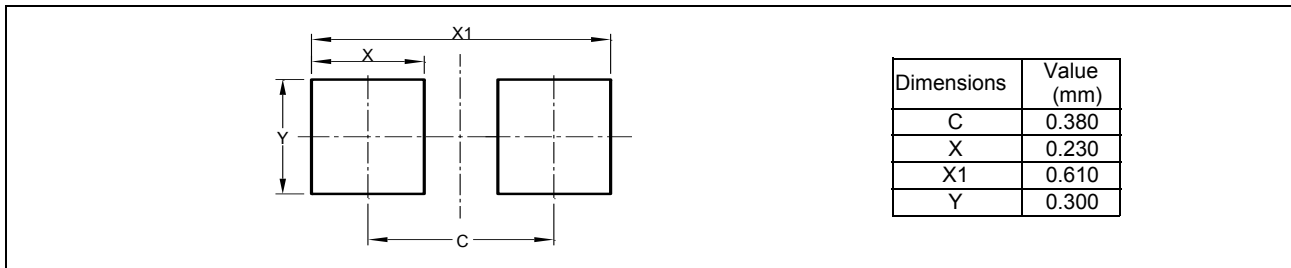

Package Information

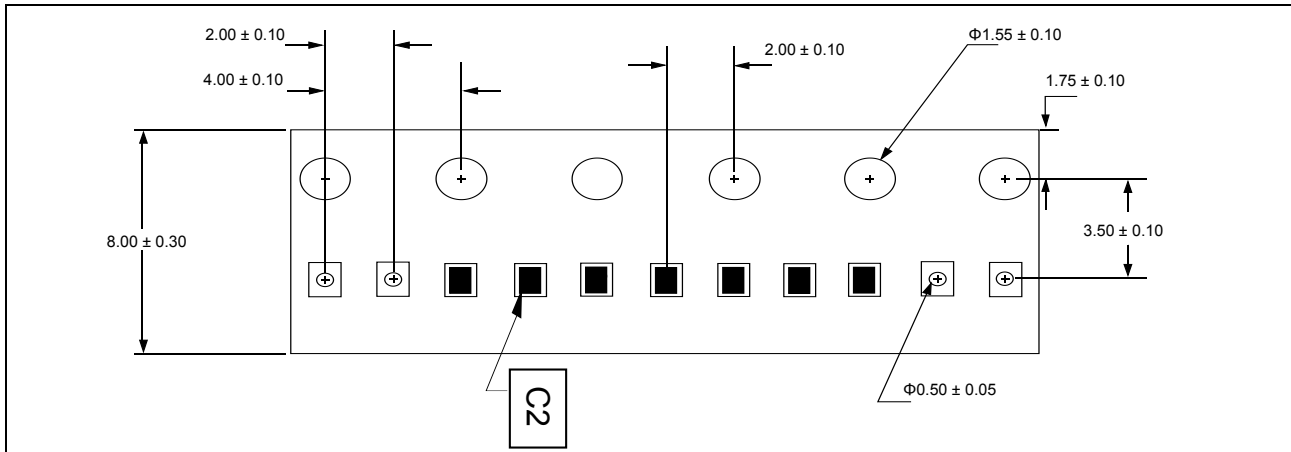

Ordering information

Order code	Marking	Package	Packaging option	Base quantity	Packaging specification
TESD0603UC5VBSH	C2	DFN0603	Tape and reel	10000pcs / reel	EIA STD RS-481