

Ultra Low Capacitance ESD/TVS Array in DFN2010

Features

- 30Watts peak pulse power ($T_P = 8/20\mu s$)
- DFN 2010 Package
- Protect up to 4-lines
- Solid-state silicon-avalanche technology
- Low clamping voltage
- Low leakage current
- Low capacitance (0.15pF typical I/O to I/O)
- ESD Protection for high-speed data lines to:
 - IEC 61000-4-2 $\pm 8KV$ contact $\pm 15KV$ air
 - IEC 61000-4-4 (EFT) 40A (5/50ns)
 - IEC 61000-4-5 (Lightning) 3A (8/20 μs)

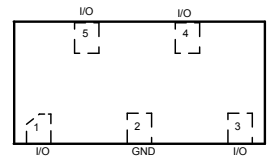
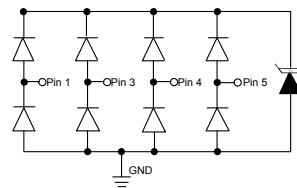
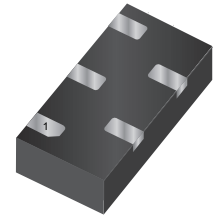

Mechanical Data

- **Case:** DFN2010 (plastic package).
Lead free; RoHS compliant; Halogen free
- **Molding Compound Flammability Rating:**
UL 94 V-0
- **Terminals:** High temperature soldering guaranteed:
260 °C/10 sec. at terminals

Applications

- USB 3.0/3.1, Type C
- HDMI 1.4/2.0, Display Port 1.3
- Unified Display interface
- Digital visual interface
- Microcontroller Input Protection

Absolute Maximum Ratings

Ratings at 25 °C, ambient temperature unless otherwise specified

| Parameter | Symbol | Value | Unit |
|---|-----------|-------------|------|
| Peak Pulse Power ($T_P=8/20\mu s$) | P_{PP} | 30 | W |
| ESD contact/air discharge (IEC-61000-4-2) | V_{ESD} | 8/15 | kV |
| Peak Pulse Current ($T_P = 8/20\mu s$) | I_{PP} | 3 | A |
| Junction Temperature | T_J | -55 to +125 | °C |
| Storage temperature | T_{STG} | -55 to +150 | °C |

Electrical Characteristics

($T_A = 25\text{ °C}$ unless otherwise specified)

| Parameter | Symbol | Condition | Min | Typ | Max | Unit |
|---------------------------|-----------|------------------------------|-----|------|-----|------|
| Reverse stand-off Voltage | V_{RWM} | | | | 5 | V |
| Reverse Breakdown Voltage | V_{BR} | $I_T=1mA$ | 6 | 7.2 | 9.5 | V |
| Reverse Leakage Current | I_R | $V_R=5V$ | | 0.1 | 0.5 | uA |
| Clamping Voltage(SURGE) | V_C | $I_{PP}=3A, T_P=8/20\mu s$ | | 10 | | V |
| Junction Capacitance | C_J | $V_R=0V, f=1MHz, I/O$ to I/O | | 0.15 | | pF |
| | C_J | $V_R=0V, f=1MHz, I/O$ to GND | | 0.2 | | pF |

Typical Characteristics (T_{amb} = 25 °C unless otherwise specified)

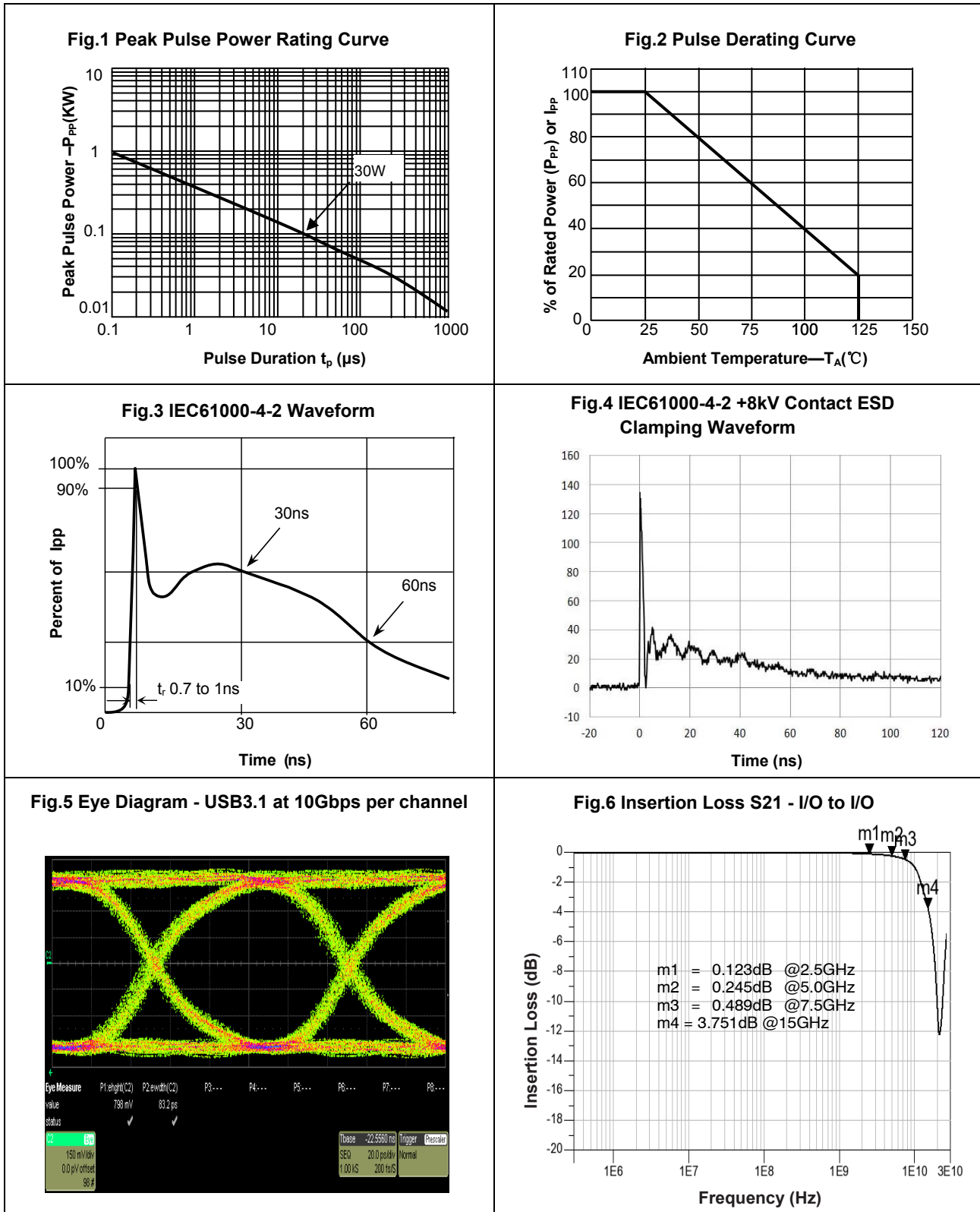

Layout Diagrams

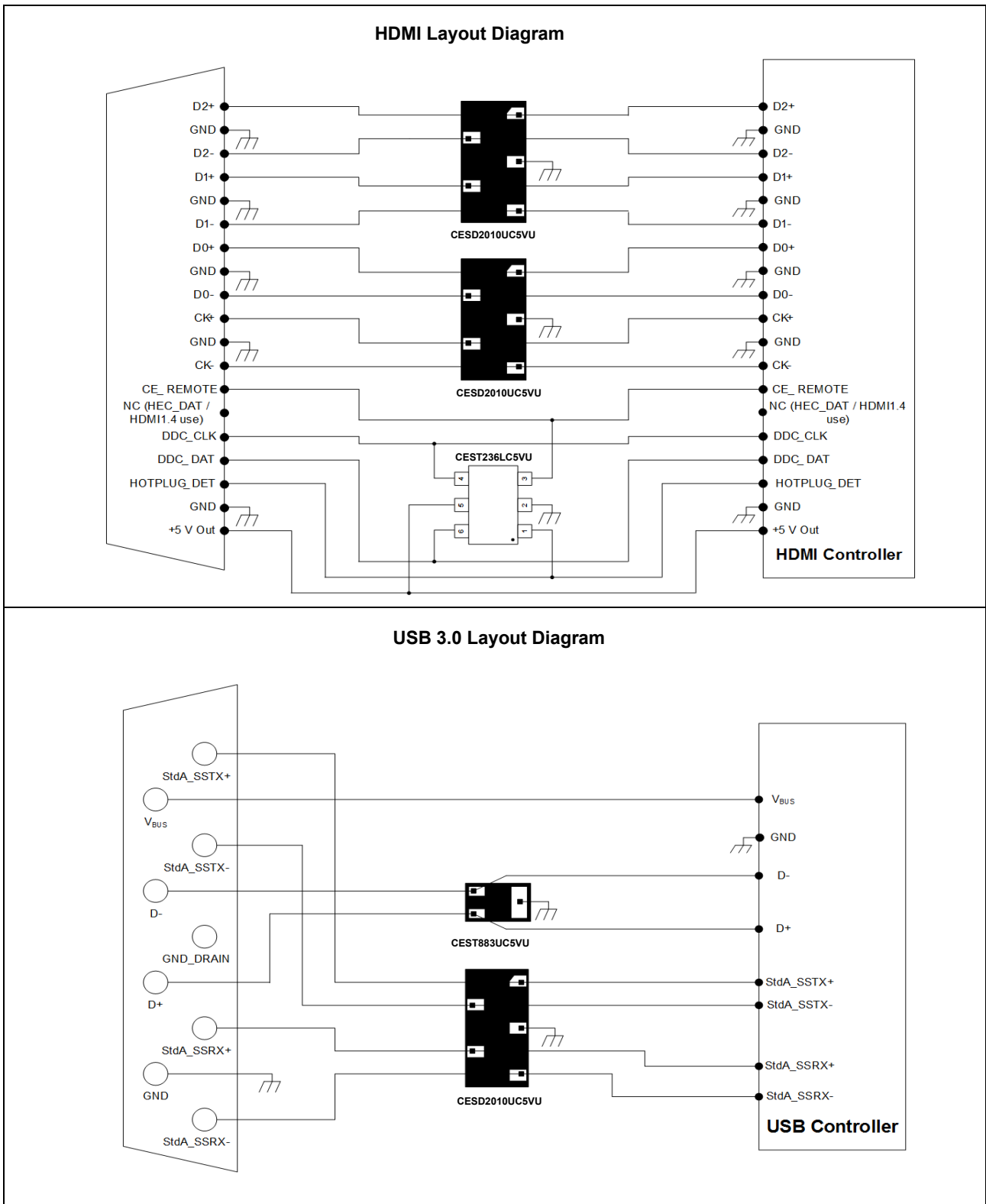

Package Dimensions

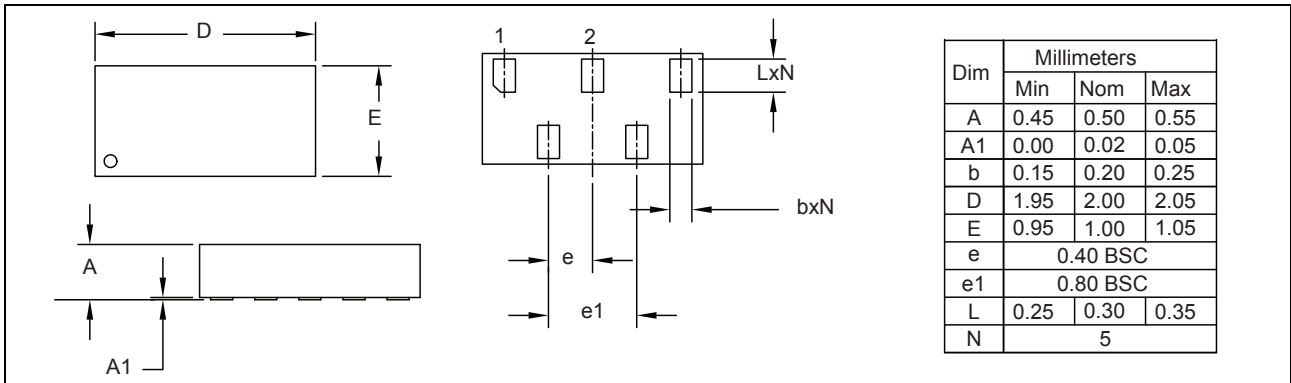

PAD DIMENSIONS

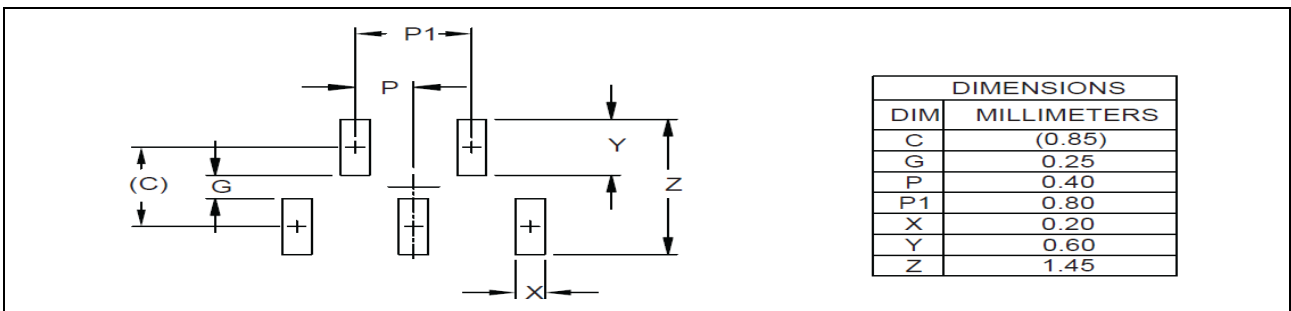

Package Information

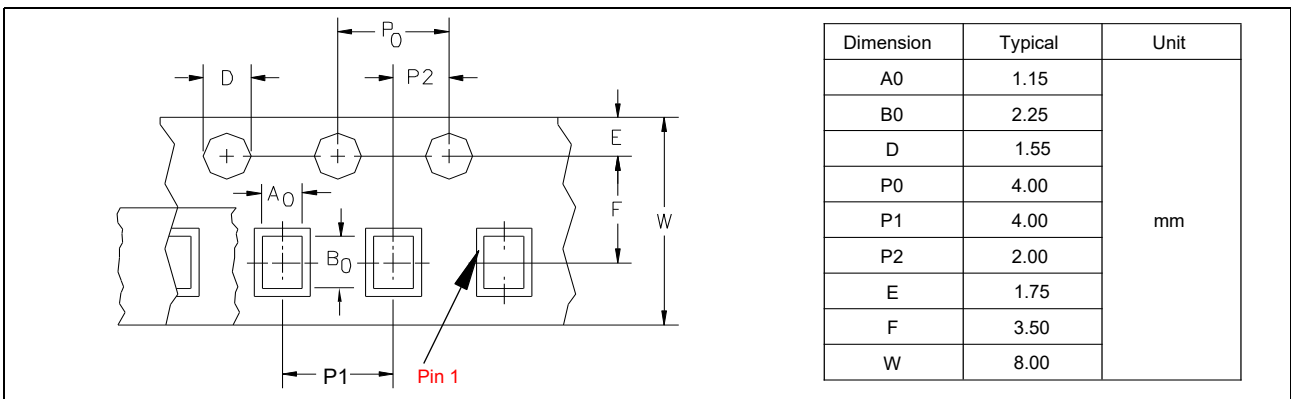

Ordering information

| Order code | Marking | Package | Packaging option | Base quantity | Packaging specification |
|---------------|---------|---------|------------------|----------------|-------------------------|
| TESD2010UC5VU | M534 | DFN2010 | Tape and reel | 3000pcs / reel | EIA STD RS-481 |