

Ultra Low Capacitance ESD TVS Array in DFN2510

Features

- 20Watts peak pulse power ($T_P = 8/20\mu s$)
- DFN2510 Package
- Unidirectional configurations
- Solid-state silicon-avalanche technology
- Low clamping voltage
- Low leakage current
- Low capacitance (0.2pF typical I/O to I/O)
- ESD Protection for high-speed data lines to:
 - IEC 61000-4-2 $\pm 8KV$ contact $\pm 15KV$ air
 - IEC 61000-4-4 (EFT) 40A (5/50ns)
 - IEC 61000-4-5 (Lightning) 4A (8/20 μs)

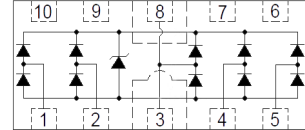
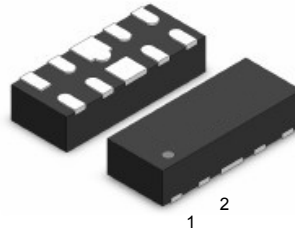

Mechanical Data

- **Case:** DFN2510 (plastic package).
Lead free; RoHS compliant; Halogen free
- **Molding Compound Flammability Rating:**
UL 94 V-0
- **Terminals:** High temperature soldering guaranteed:
260 °C/10 sec. at terminals

Applications

- USB 3.1, USB 3.0, MHL
- HDMI 2.0, Display Port 1.3, eSATA
- Unified Display Interface (UDI)
- Digital Visual Interface (DVI)
- High speed serial interfaces

Absolute Maximum Ratings

Ratings at 25 °C, ambient temperature unless otherwise specified

Parameter	Symbol	Value	Unit
Peak Pulse Power ($T_P=8/20\mu s$)	P_{PP}	20	W
ESD contact/air discharge (IEC-61000-4-2)	V_{ESD}	8/15	kV
Peak Pulse Current ($T_P = 8/20\mu s$)	I_{PP}	4.0	A
Junction Temperature	T_J	-55 to +125	°C
Storage temperature	T_{STG}	-55 to +150	°C

Electrical Characteristics

($T_A = 25\text{ °C}$ unless otherwise specified)

Parameter	Symbol	Condition	Min	Typ	Max	Unit
Reverse stand-off Voltage	V_{RWM}				3.3	V
Holding Voltage	V_H	$I_T=I_H$	2.5			V
Holding Current	I_H		30			mA
Reverse Leakage Current	I_R	$V_{RWM}=3.3V$			0.5	uA
Clamping Voltage	V_C	$I_{PP}=4A, T_P=8/20\mu s$		5.0		V
Clamping Voltage(TLP)	V_C	$I_{PP}=16A, T_P=100ns$		6.0		V
Dynamic Resistance	R_{dyn}			0.2		Ω
Junction Capacitance	C_J	$V_R=0V, f=1MHz, I/O$ to I/O		0.20		pF
	C_J	$V_R=0V, f=1MHz, I/O$ to GND		0.40		pF

Typical Characteristics ($T_{amb} = 25\text{ }^{\circ}\text{C}$ unless otherwise specified)

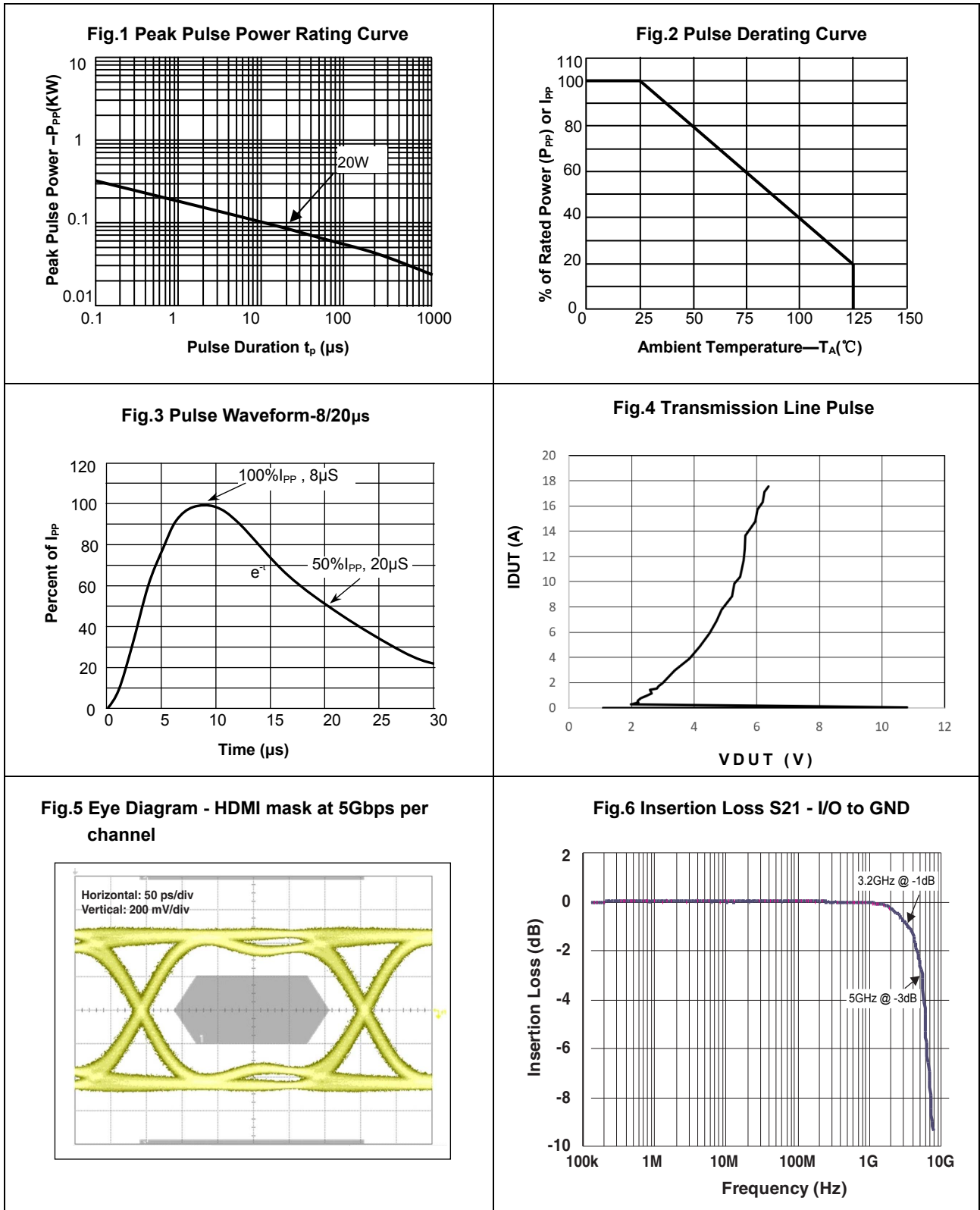

Package Dimensions

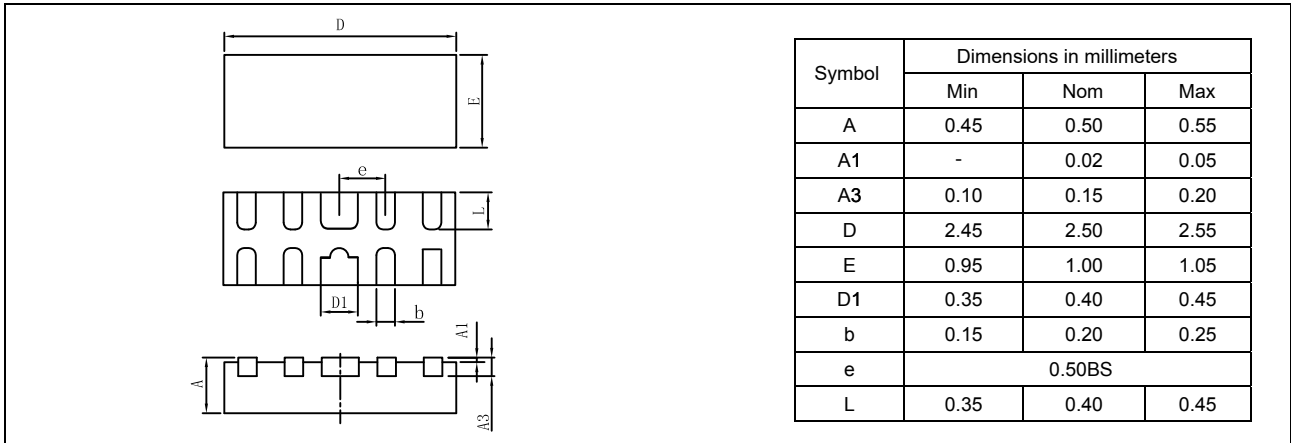

Pad Dimensions

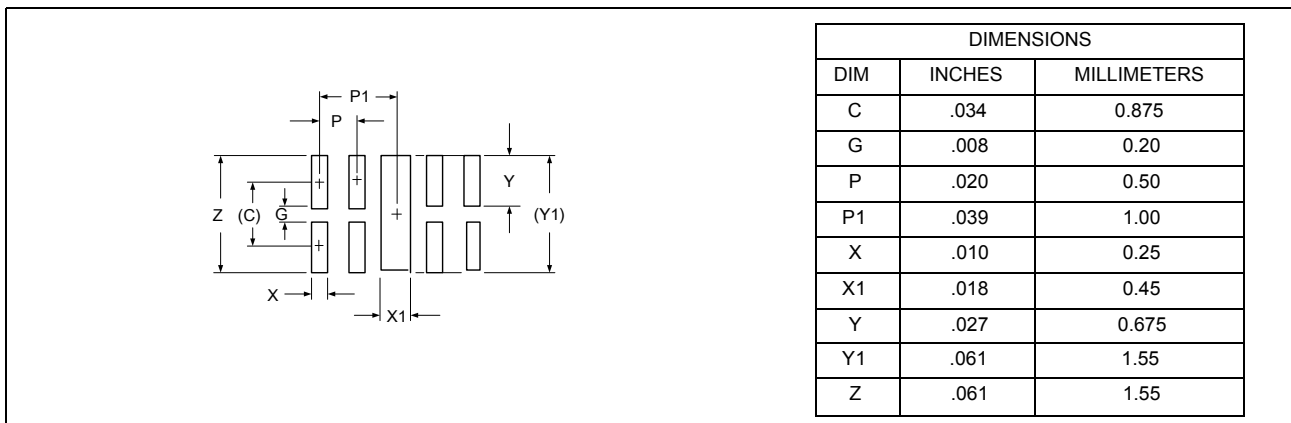

Package Information

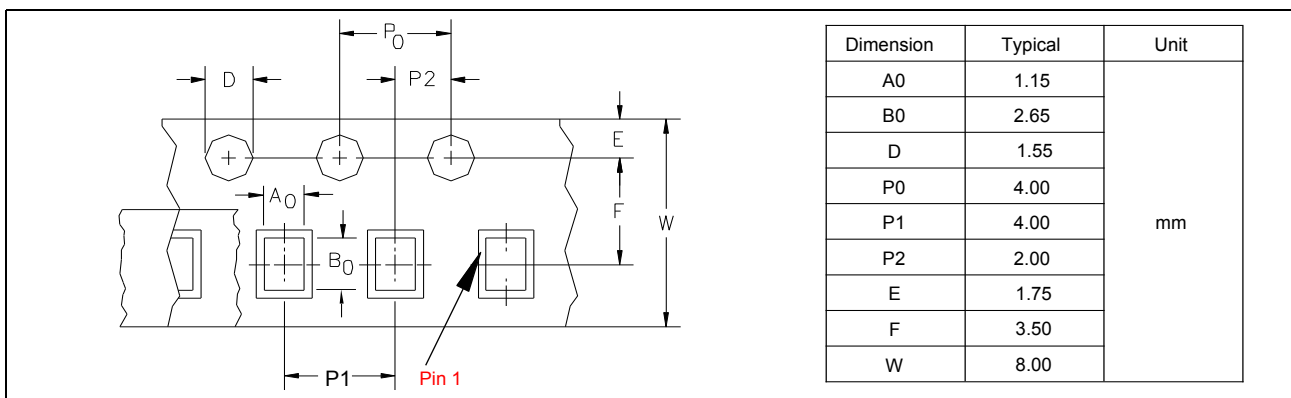

Ordering information

Order code	Marking	Package	Packaging option	Base quantity	Packaging specification
TESD2510UC3V3USH	33U	DFN2510	Tape and reel	3000pcs / reel	EIA STD RS-481