

## Ultral Low Capacitance ESD Protection Diode in 0603

### Features

- Very low leakage current
- Fast response time
- Bidirectional configurations
- Very low leakage current
- Response time is typically <math><1\text{ns}</math>
- Extremely low capacitance ( $C_j=0.05\text{pF}$  typ.)
- The best ESD protection for high frequency, low voltage applications
- Protection one data line to:  
IEC 61000-4-2  $\pm 30\text{kV}$  contact  $\pm 30\text{kV}$  air

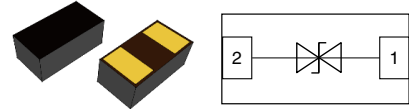

### Mechanical Data

- **Case:** 0603 (plastic package).  
Lead free; RoHS compliant; Halogen free
- **Molding Compound Flammability Rating:**  
UL 94 V-0
- **Terminals:** High temperature soldering guaranteed:  
260 °C/10 sec. at terminals

### Applications

- USB3.0, Firewire, DVI, HDMI, S-ATA
- Thunderbolt, Display Port
- Mobile HDMI Link, MDDI, MIPI, SWP / NFC



Caution:  
This component is designed for signal line protection only, Not intended to be used under bias, not for application with a power line.

### Absolute Maximum Ratings

Ratings at 25 °C, ambient temperature unless otherwise specified

Parameter	Symbol	Value	Unit
Maximum Contact discharge voltage Per IEC61000-4-2	$V_{ESD}$	30	kV
Maximum Air discharge voltage Per IEC61000-4-2	$V_{ESD}$	30	kV
Operating temperature	$T_{Oper}$	-40 to +125	°C
Storage temperature	$T_{STG}$	-55 to +125	°C
Maximum Lead Solder Temperature(10 second duration)	$T_L$	260	°C

### Electrical Characteristics

( $T_A = 25\text{ °C}$  unless otherwise specified)

Parameter	Symbol	Condition	Min	Typ	Max	Unit
Rated Voltage	$V_R$	---			18	V
Trigger voltage	$V_T$	IEC61000-4-2 8KV contact discharge		350		V
Leakage current	$I_L$	DC 12V shall be applied on component			0.1	uA
Clamping Voltage	$V_C$	IEC61000-4-2 8KV contact discharge		35		V
Junction Capacitance	$C_J$	$V_R=0V, f=1\text{MHz}$		0.05		pF

Note: 1. Trigger and clamping voltage are measured per IEC 61000-4-2, 8KV contact discharge method.  
2. After reliability tests such as high temp storage, temp cycles, continuous ESD strike etc, the maximum leakage current is less than 10uA.

## ESD Clamping Test

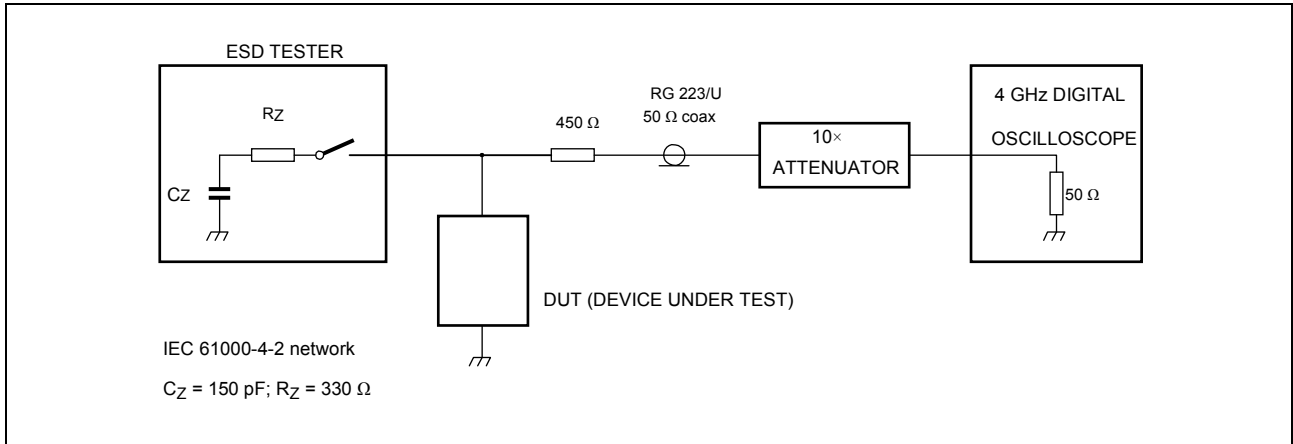

## Typical Characteristics

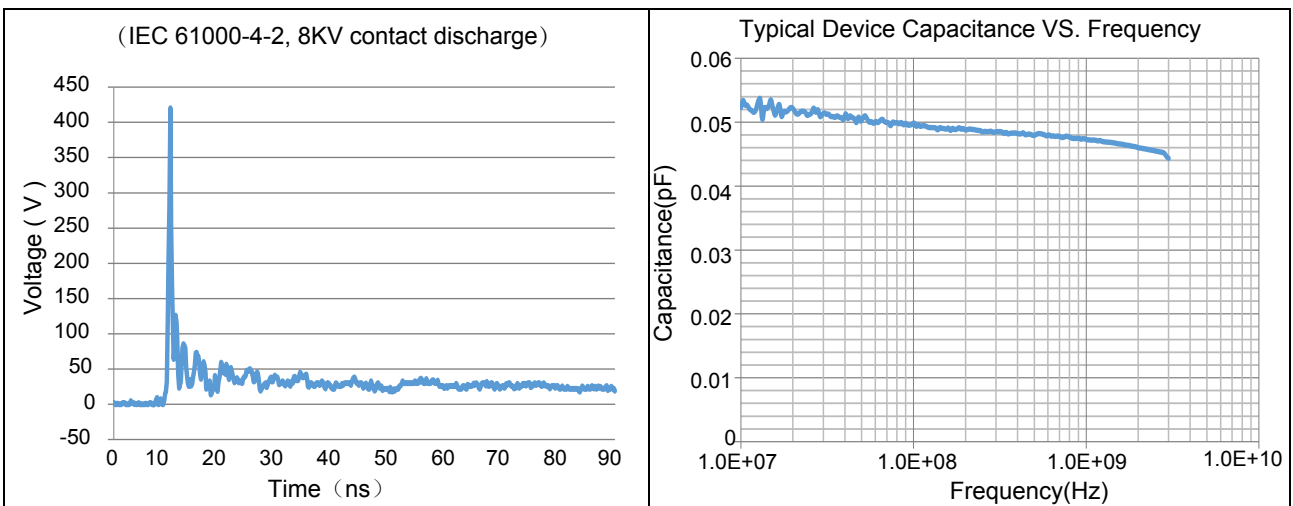

## ESD Protection for Signal Line

The CESD is designed for the protection of one bidirectional data line from ESD damage.

- Place the CESD as close to the input terminal or connector as possible.
- Minimize the path length between the CESD and the protected signal line.
- Use ground planes whenever possible.

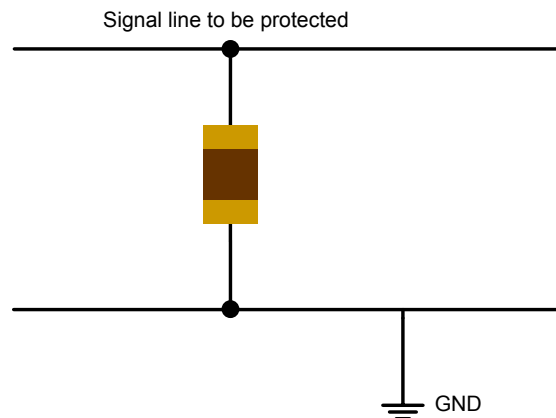

## Product Dimension

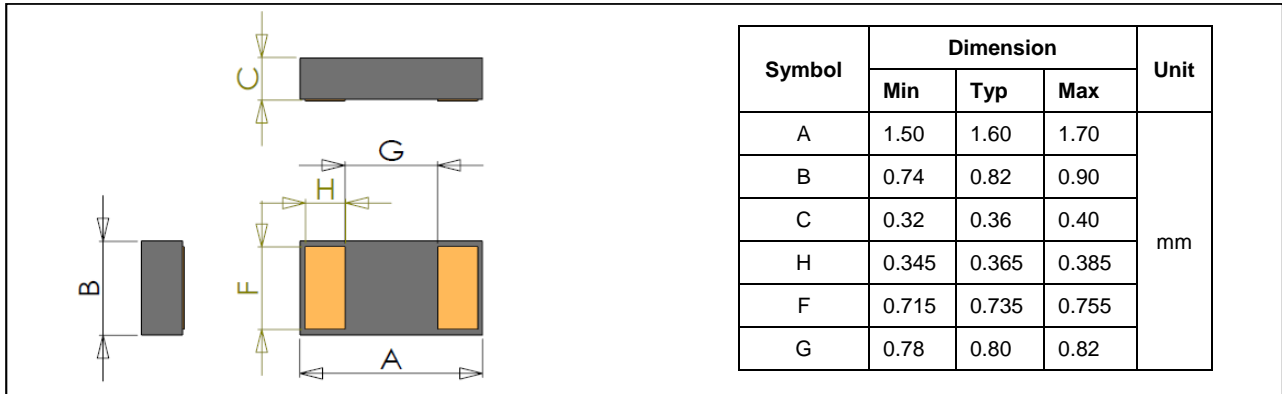

## PAD Dimension

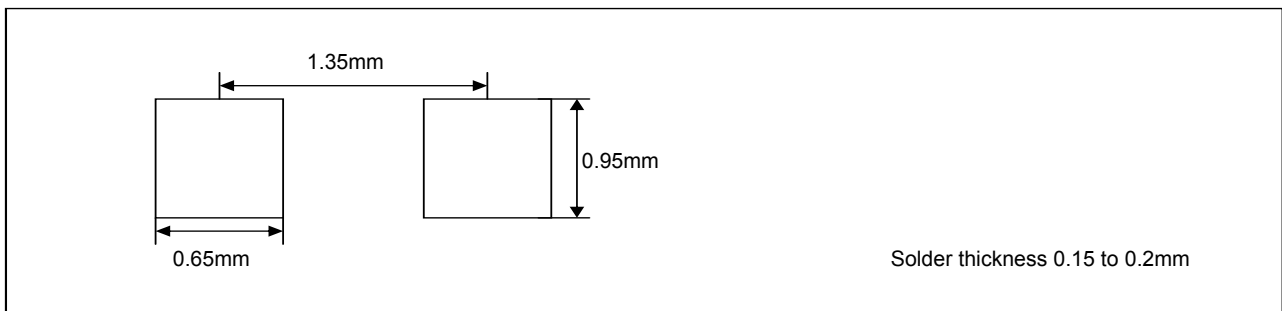

## Solder Reflow Recommendations

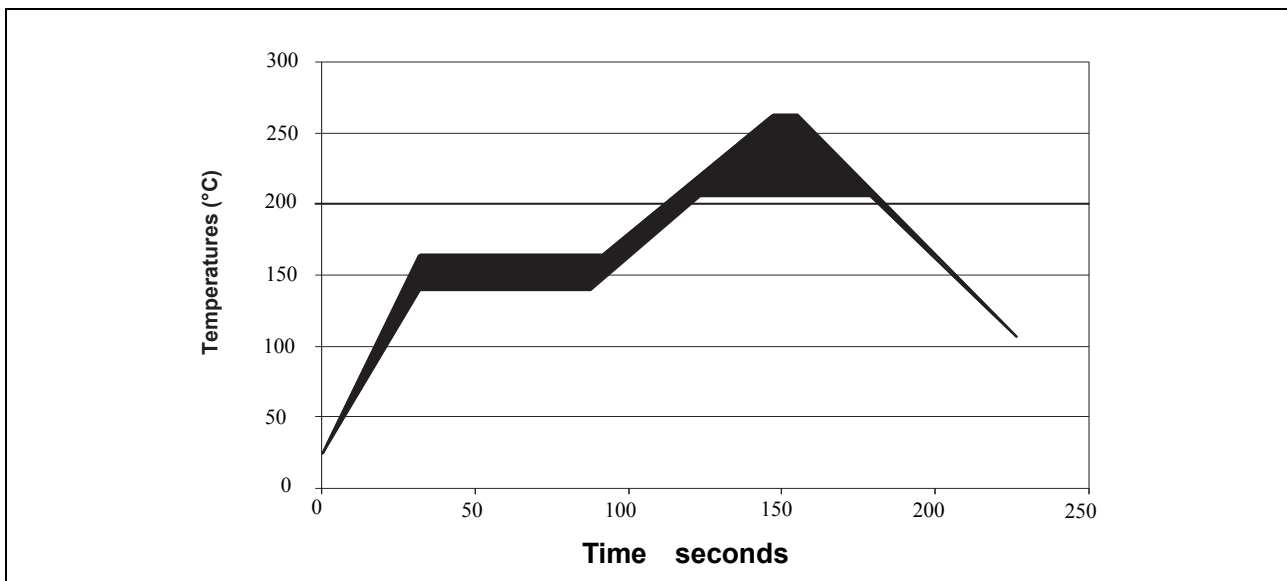

## Package Information

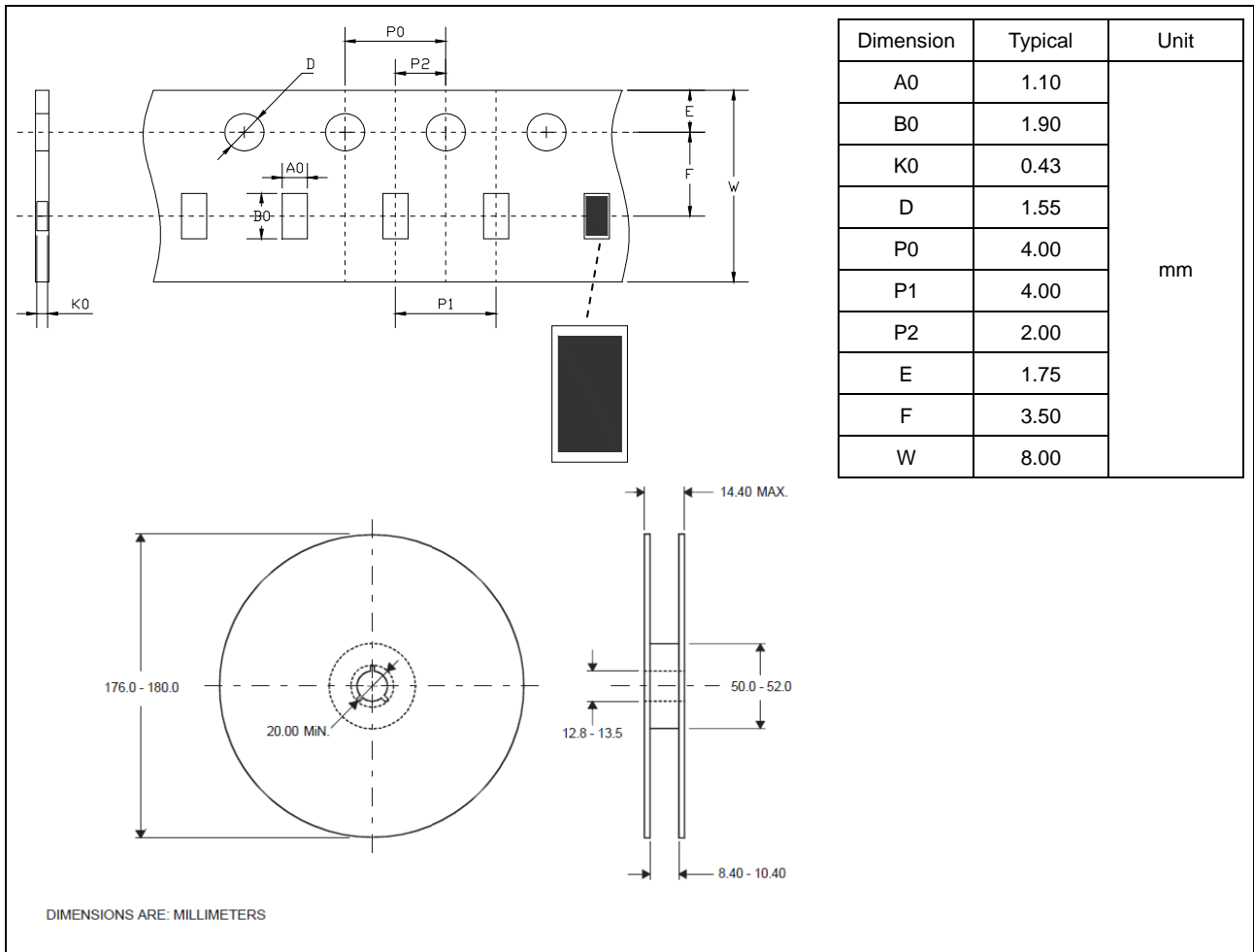

## Ordering information

Order code	Package	Packaging option	Base quantity	Packaging specification
TESDP0603UC18VB	0603	Tape and reel	5000pcs / reel	EIA STD RS-481