

Low Capacitance ESD TVS Array in SOT143

Features

- 100Watts peak pulse power ($t_p = 8/20\mu s$)
- SOT143 Package
- Unidirectional configurations
- Solid-state silicon-avalanche technology
- Low clamping voltage
- Low leakage current
- Low capacitance
- ESD Protection for high-speed data lines to:
 - IEC 61000-4-2 $\pm 15kV$ contact $\pm 20kV$ air
 - IEC 61000-4-4 (EFT) 40A (5/50ns)
 - IEC 61000-4-5 (Lightning) 6A (8/20 μs)

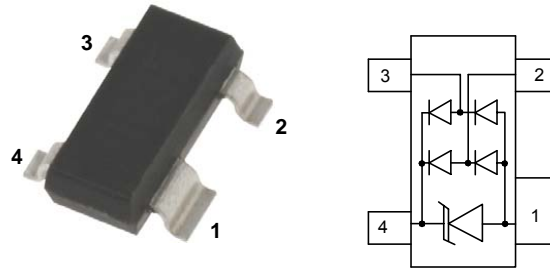

Mechanical Data

- **Case:** SOT143 (plastic package).
Lead free; RoHS compliant; Halogen free
- **Molding Compound Flammability Rating:**
UL 94 V-0
- **Terminals:** High temperature soldering guaranteed:
260 °C/10 sec. at terminals

Applications

- USB2.0
- Ethernet 10BaseT
- I²C Bus Protection
- T1/E1 secondary IC Side Protection
- ISDN S/T Interface

Absolute Maximum Ratings

Ratings at 25 °C, ambient temperature unless otherwise specified

Parameter	Symbol	Value	Unit
Peak Pulse Power ($T_P=8/20\mu s$)	P_{PP}	100	W
ESD contact/air discharge (IEC-61000-4-2)	V_{ESD}	15/20	kV
Peak Pulse Current ($T_P = 8/20\mu s$)	I_{PP}	6	A
Junction Temperature	T_J	-55 to +125	°C
Storage temperature	T_{STG}	-55 to +150	°C

Electrical Characteristics

($T_A = 25\text{ °C}$ unless otherwise specified)

Parameter	Symbol	Condition	Min	Typ	Max	Unit
Reverse stand-off Voltage	V_{RWM}				5	V
Reverse Breakdown Voltage	V_{BR}	$I_T=1mA$	6	6.8	8.5	V
Reverse Leakage Current	I_R	$V_R=5V$			5	μA
Clamping Voltage(SURGE)	V_C	$I_{PP}=1A, T_P=8/20\mu S$			9.8	V
Clamping Voltage(SURGE)	V_C	$I_{PP}=6A, T_P=8/20\mu S$		15		V
Junction Capacitance	C_J	$V_R=0V, f=1MHz, I/O$ to I/O		0.3		pF
	C_J	$V_R=0V, f=1MHz, I/O$ to GND		0.6		pF

Typical Characteristics ($T_{amb} = 25\text{ }^{\circ}\text{C}$ unless otherwise specified)

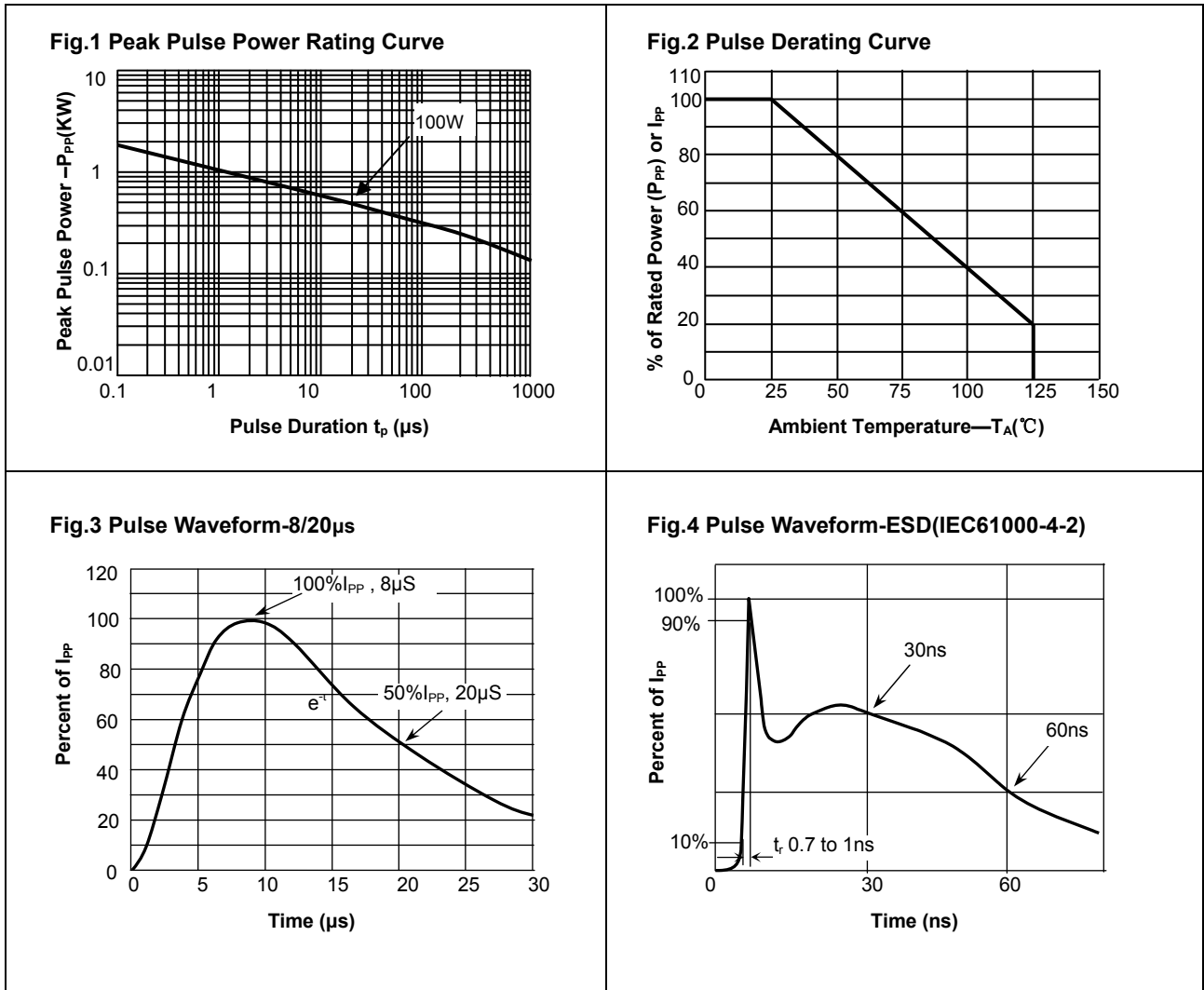

Package Dimensions

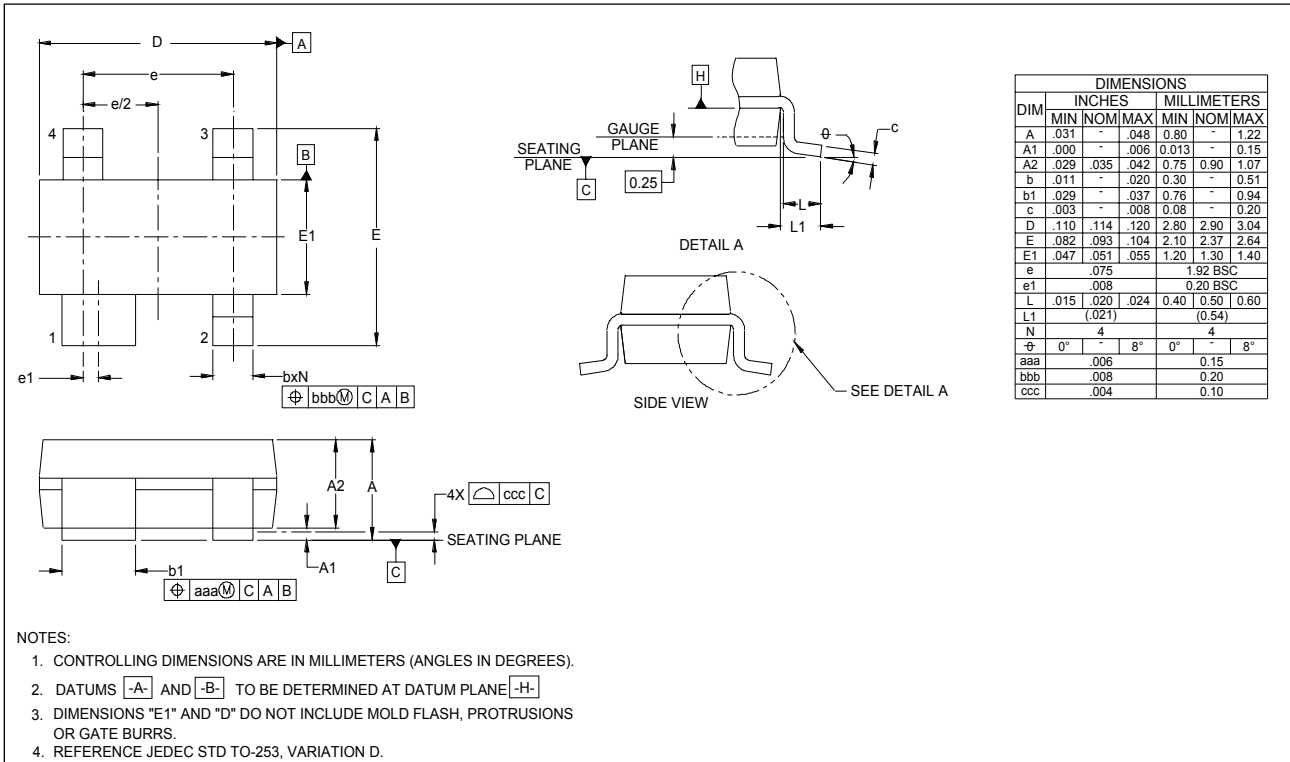

Pad Dimensions

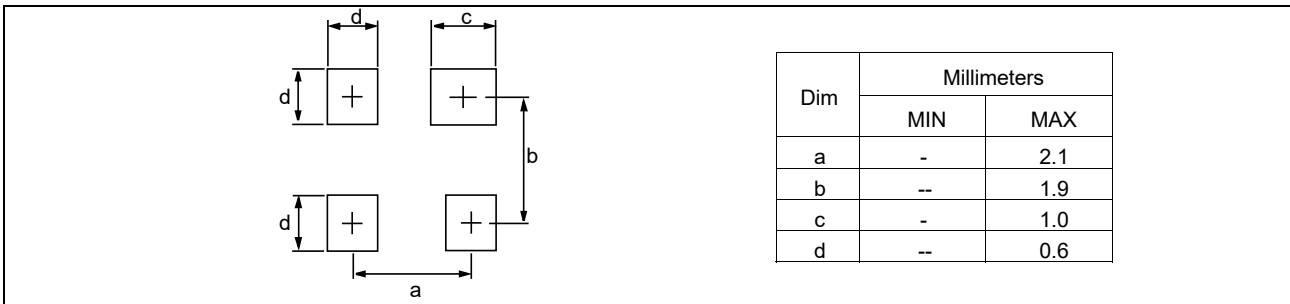

Marking



Ordering information

Order code	Package	Packaging option	Base quantity	Packaging specification
TCEST143LC5VU	SOT-143	Tape and reel	3000pcs / reel	EIA STD RS-481