

Low Capacitance ESD/TVS Array in SOT23-6

Features

- 100Watts peak pulse power ($t_p = 8/20\mu s$)
- SOT23-6 Package
- Solid-state silicon-avalanche technology
- Low clamping voltage
- Low leakage current
- Low capacitance(1.2pF typical,Line to Line)
- ESD capability according to AEC-Q101:
human body model: class H3B: > 8 kV
- ESD Protection for high-speed data lines to:
 - IEC 61000-4-2 $\pm 30kV$ contact $\pm 30kV$ air
 - IEC 61000-4-4 (EFT) 40A (5/50ns)
 - IEC 61000-4-5 (Lightning) 10 A (8/20 μs)

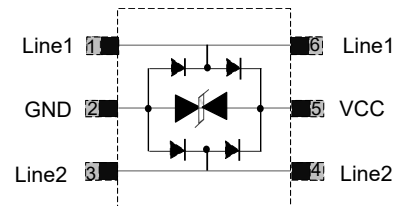
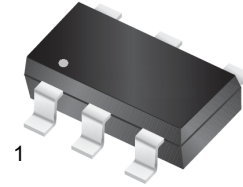

Mechanical Data

- **Case:** SOT23-6 (plastic package).
Lead free; RoHS compliant; Halogen free
- **Molding Compound Flammability Rating:**
UL 94 V-0
- **Terminals:** High temperature soldering guaranteed:
260 °C/10 sec. at terminals

Applications

- USB 2.0, MHL
- Ethernet
- Unified Display Interface (UDI)
- Digital Visual Interface (DVI)

Absolute Maximum Ratings

Ratings at 25 °C, ambient temperature unless otherwise specified

Parameter	Symbol	Value	Unit
Peak Pulse Power ($T_P=8/20\mu s$)	P_{PP}	100	W
ESD contact/air discharge (IEC-61000-4-2)	V_{ESD}	30/30	kV
Peak Pulse Current ($T_P = 8/20\mu s$)	I_{PP}	40	A
Junction Temperature	T_J	-55 to +150	°C
Storage temperature	T_{STG}	-55 to +150	°C

Electrical Characteristics ($T_A = 25\text{ }^\circ\text{C}$ unless otherwise specified)

Parameter	Symbol	Condition	Min	Typ	Max	Unit
Reverse Stand-Off Voltage	V_{RWM}				3.3	V
Reverse Breakdown Voltage	V_{BR}	$I_T=1mA$	4.0			V
Reverse Leakage Current	I_R	$V_{RWM}=3.3V, T=25^\circ C$			0.5	μA
Clamping Voltage	V_C	$I_{PP}=40A, t_p=8/20\mu s$			20	V
Junction Capacitance	C_j	$V_R = 0V, f = 1MHz$ Line to Line		1.2		pF
		$V_R = 0V, f = 1MHz$ Line to GND		2.2		pF

Typical Characteristics ($T_{amb} = 25\text{ }^{\circ}\text{C}$ unless otherwise specified)

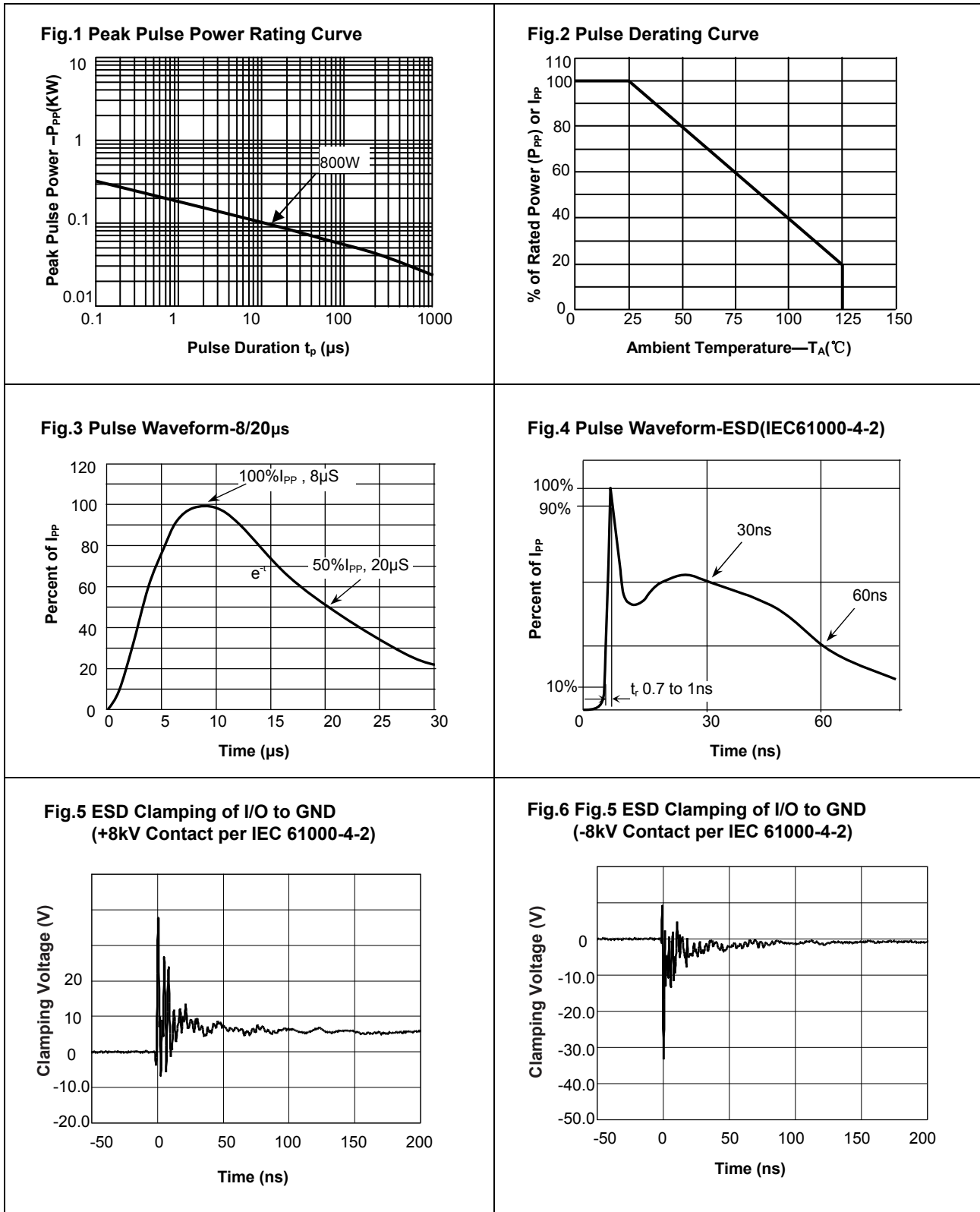

Package Dimensions

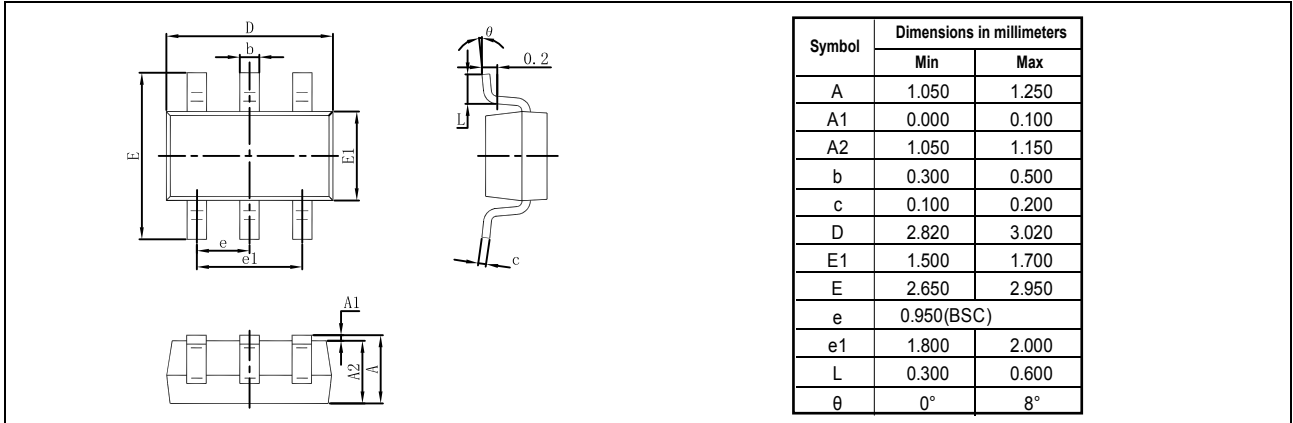

Pad dimensions

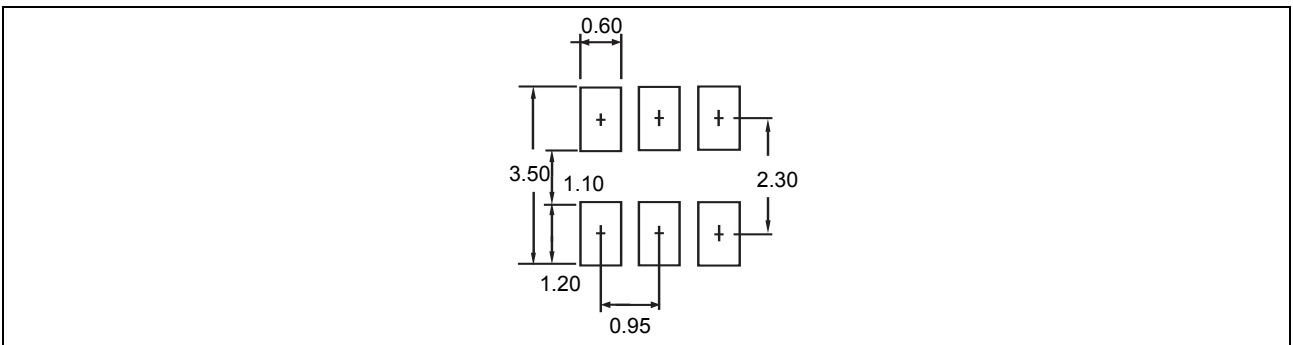

Package information

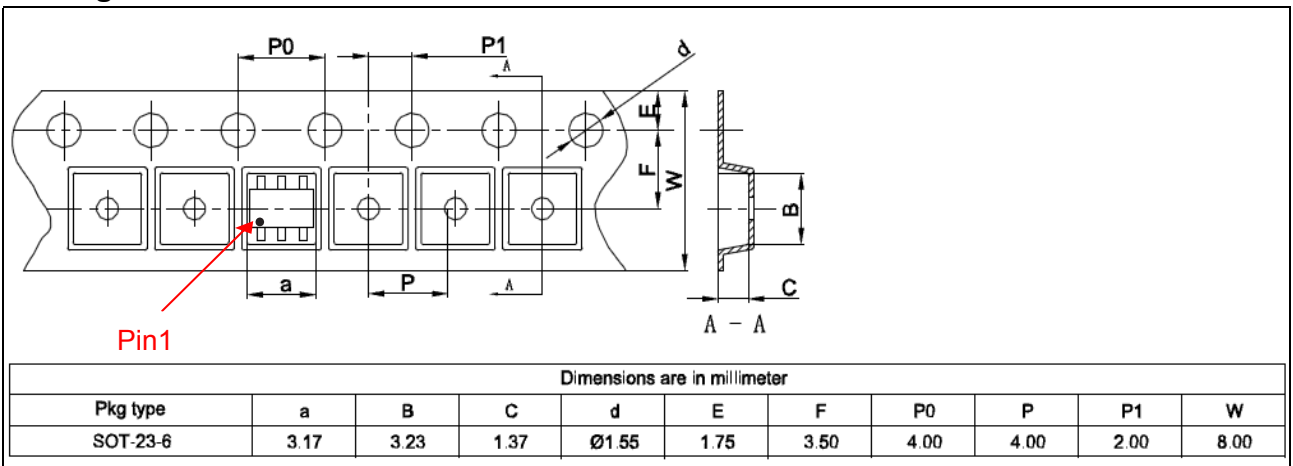

Ordering information

Order code	Marking	Package	Packaging option	Base quantity	Packaging specification
TEST236LC3V3BTH	E33	SOT23-6	Tape and reel	3000pcs / reel	EIA STD RS-481